

BOSCH

Invented for life

LBC 3099/41 Ceiling Loudspeaker



The LBC 3099/41 is a flush-mounting ceiling loudspeaker for applications where extra power is required, such as rooms with high ceilings. It delivers a high sound pressure level and has a wide frequency range to ensure excellent speech intelligibility and good quality music reproduction. It is used in applications like shops, department stores, schools, offices, sports halls, hotels and restaurants.

Functions

The LBC 3099/41 has a single-piece, 24 W, dual-cone loudspeaker. A 100 V matching transformer is mounted on the back of the frame. An attractive metal grille is integrated with the front, and finished in an unobtrusive white color (RAL 9010).

Voice alarm loudspeaker

Voice alarm loudspeakers are specifically designed for use in buildings where performance of systems for verbal evacuation announcements is governed by regulations. The LBC 3099/41 is designed for use in voice alarm systems and is compliant with EVAC standards.

- ▶ Excellent speech and music reproduction
- ▶ High sound pressure level
- ▶ Ideal for high-ceiling applications
- ▶ Flush mounted in ceilings
- ▶ Clamp mounting
- ▶ Simple power setting
- ▶ Unobtrusive white metal grille
- ▶ Ball-proof
- ▶ Complies with international installation and safety regulations
- ▶ Compliant with EVAC standards

The loudspeaker has built-in protection to ensure that, in the event of a fire, damage to the loudspeaker does not result in failure of the circuit to which it is connected. In this way, system integrity is maintained, ensuring loudspeakers in other areas can still be used to inform people of the situation. The loudspeaker has a ceramic terminal block, thermal fuse and heat resistant, high-temperature wiring. It can also be fitted with an optional fire-dome LBC 3082/00 to increase protection of the cable termination.

Certifications and Approvals

All Bosch loudspeakers are designed to withstand operating at their rated power for 100 hours in accordance with IEC 268-5 Power Handling Capacity (PHC) standards. Bosch has also developed the Simulated Acoustical Feedback Exposure (SAFE) test to demonstrate that they can withstand two times their rated power for short durations. This ensures extra reliability under extreme conditions, leading to higher customer satisfaction, longer operating life, and much less chance of failure or performance deterioration.

Region	Certification
Europe	CE

Safety	acc. to EN 60065
EVAC	acc. to BS 5839-8
Ball-proof	acc. to DIN 18032-3

Installation/Configuration Notes



LBC 3099/41 with LBC 3082/00 fire dome assembly

The unit has two built-in spring-loaded locking clamps to secure it into a hole in suspended ceilings and wallboards from 9 to 25 mm (0.35 to 1.0 in) thick. A circular template for marking a 210 mm (8.3 in) diameter hole is included with the loudspeaker.

Terminal Block

The unit has a three-way terminal block with screw connections (including earth) suitable for loop-through wiring. Three primary taps are provided on the matching transformer to allow selection of nominal full-power, half-power or quarter-power radiation (in 3 dB steps).

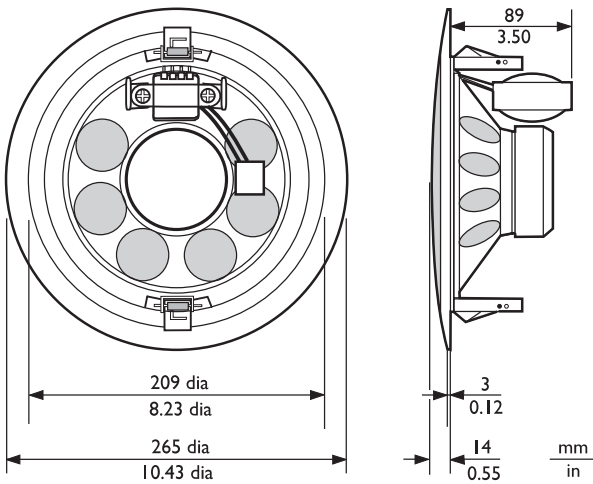

Dimensions in mm (in)

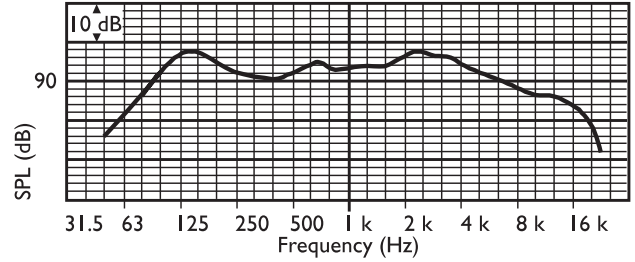

Frequency response

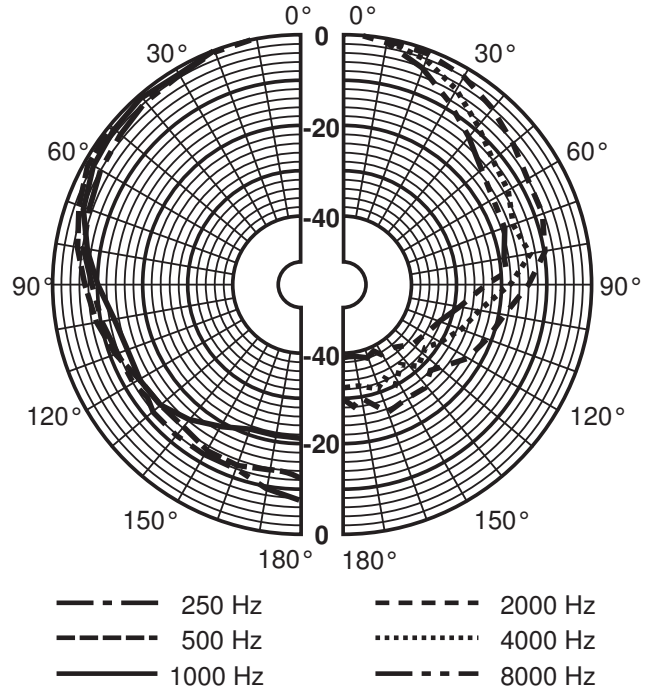

Polar diagram (measured with pink noise)

	125 Hz	250 Hz	500 Hz	1 kHz	2 kHz	4 kHz	8 kHz
SPL 1.1	94	92	90	92	94	93	86
SPL max.	108	106	104	106	108	107	100
Q-factor	3.7	4.5	2.8	5.2	8.9	17.4	34
Efficiency	0.85	0.44	0.63	0.38	0.36	0.14	0.02
H. angle	180	180	180	160	90	60	40
V. angle	180	180	180	160	90	60	40

Acoustical performance specified per octave

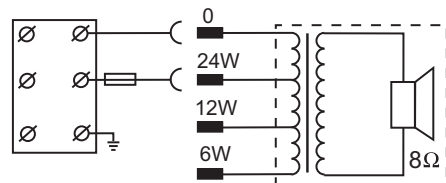

Circuit diagram

Parts Included

Quantity	Components
1	LBC 3099/41 Ceiling Loudspeaker
1	210 mm (8.3 in) circular template

Technical Specifications

Electrical*

Maximum power	36 W
Rated power (PHC)	24 / 12 / 6 W
Sound pressure level at 24 W / 1 W (1 kHz, 1 m)	106 dB / 92 dB (SPL)
Sound pressure level at 24 W / 1 W (4 kHz, 1 m)	107 dB / 93 dB (SPL)
Effective frequency range (-10 dB)	60 Hz to 18 kHz
Opening angle at 1 kHz/4 kHz (-6 dB)	160° / 60°
Rated voltage	100 V
Rated impedance	417 ohm
Connector	3-pole screw terminal block

* Technical performance data acc. to IEC 60268-5

Mechanical

Diameter	265 mm (10.4 in)
Maximum depth	89 mm (3.5 in)
Mounting cut-out	210 mm (8.3 in)
Speaker diameter	203.2 mm (8 in)
Weight	1.8 kg (4 lb)
Color	White (RAL 9010)
Magnet weight	283 g (10 oz)

Environmental

Operating temperature	-25 °C to +55 °C (-13 °F to +131 °F)
Storage temperature	-40 °C to +70 °C (-40 °F to +158 °F)
Relative humidity	<95%

Ordering Information

LBC 3099/41 Ceiling Loudspeaker **LBC3099/41**

24 W, dual-cone loudspeaker. A 100 V matching transformer is mounted on the back of the frame.

Accessories

LBC 3082/00 Fire Dome **LBC 3082/00**

metal fire dome for LBC 3099/41 ceiling loudspeaker